

Technical Data Sheet

Series: **Kube**

Article code: **100NN8515 02**

Description:

One hole basin mixer, click clack waste, antitorsion flex cm 50 x 1/2" F.

Materials:

Brass

Surface finish Matt Black



Finishing



Features



Cartridge diam. 25 mm with 2 ceramic disks, with 25° opening angle, and 90° mixing angle. We use only certified white lubricant into our mixers and cartridges.



Aerator Male thread 24 x 1
Flow rate 7 l/min at 3 bar



Stainless steel flex hoses cm 50 with 1/2 brass nut with internal non removable rubber



Metal pop up waste click clack



Easy installation with 65 mm brass long fixing screw
Suitable for electrical water heater

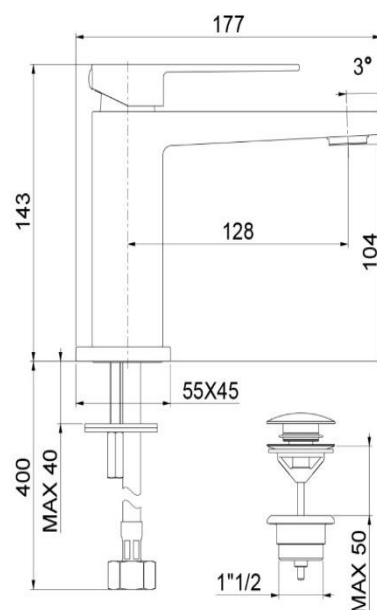

Technical Data Sheet

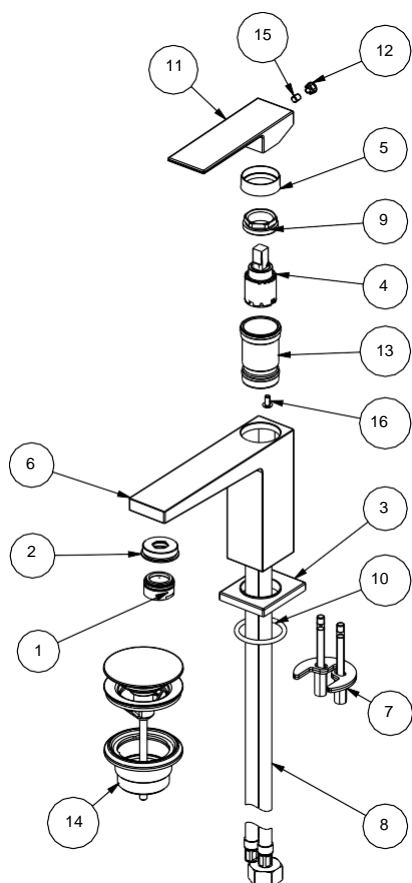

01	M24x1 aerator	
02	Aerator holder	Brass
03	Base	Brass
04	Cartridge d. 25	/
05	Cap	Brass
06	Body	Brass
07	Fixing set	/
08	Antitorsion flexible hoses 50 cm	/
09	Locking nut	Brass
10	OR	Rubber
11	Lever	Zamac
12	Plaquette	Chrome ABS
13	Cartridge holder	Brass
14	Click clack waste	/
15	Screw M5x6	Steel
16	Screw M4x10	Steel

Maintenance

Product care also includes regularly cleaning the aerator filter from impurities and/or lime scale. For correct decalcification, disassemble the aerator and place it into diluted vinegar (max concentration: 10% at 20°C) to remove lime scale deposits and/or dirt from the aerator filters. Leave it to soak for a few hours, and then rinse using only water.

Cleaning recommendation for products and care of finish

Chrome: the chrome surfaces can be cleaned with a mild detergent or with neutral soap and water.

Color finishes: taps with colored finishes should be cleaned only with a cloth and water.

Never use detergents containing mineral acids (ex. hydrochloric acid), aggressive acids (ex. acetic acid), bases (ex. ammonia) phosphoric acid or other aggressive substances, as they can cause significant damage.



www.fiore.it/catalogues