

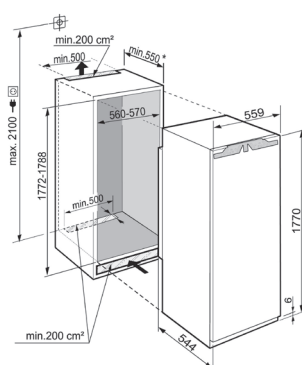

PROJECT		DETAILED SPECIFICATIONS	BUILT-IN FREEZER
LOCATION	KITCHEN	ITEM CODE	IGN 3566 PREMIUM NO FROST
FINISH	WHITE	MANUFACTURE	LIEBHERR DATE 09/07/2020

### Features



#### Output and Consumption

Energy efficiency class	A++
Energy consumption in 24h	0.668 kWh / 24h
Energy consumption per year	244 kWh/a
Climate class	SN-T
Noise level	38 dB
Net capacity, total	213 l
Gross capacity, total	248 l
Voltage	220-240 V ~
Frequency	50 Hz
Connection rating	1.3 A 251 W

#### Dimension and Weight

Aperture height	178 cm
Dimension (packaged), H/W/D	1,835.0 / 572.0 / 622.0 mm
Aperture dimensions height/width/depth	177.2 - 178.8 / 56 - 57 / 55.0 cm
Weight (without packaging)	82.5 kg
Weight (with packaging)	87.0 kg

#### Control and Functions

Control	Magic Eye with LC and digital temperature display
Control unit	Touch-Electronic
Temperature display	Freezer compartment optical and acoustical
Malfunction: Warning signal	
Door open: Warning signal, freezer compartment	Audible
SuperFrost	Quantity-controlled
SoftSystem	SoftSystem

#### Freezer Compartment

Star-coding	4
Cooling technology	No Frost
Storage time during interruptions in power supply	14 h
Freezing capacity in 24 hrs	18 kg
Drawers	8
Storage shelf material, freezer compartment	Glass
Lighting	LED lighting
Cold storage accumulators	2

#### Set - up and Installation

Door assembly	Door-on-door
Door hinges	Right interchangeable
Door opening angle	115°
Ventilation	Kitchen unit ventilation

CONTACT :  
MOBILE :  
E-MAIL :

#### MVP APPLIANCES

No. 1,11 B Street, Al Quoz Industrial Area 4, Dubai - UAE  
Tel : +971 4 380 9490 | Fax : +971 4 346 5614  
WEBSITE: www.mvpappliances.com