

PROJECT	<input type="text"/>	DETAILED SPECIFICATIONS	<input type="text" value="NO FROST FULLY INTEGRATED FRIDGE"/>
LOCATION	<input type="text"/>	ITEM CODE	<input type="text" value="SIGN 3576 PREMIUM"/>
FINISH	<input type="text" value="STAINLESS STEEL"/>	MANUFACTURE	<input type="text" value="LIEBHERR"/> DATE <input type="text" value="13/12/2023"/>

Features



Output and Consumption

Energy consumption in 24h	0.906 kWh / 24h
Energy consumption per year	331 kWh/a
Climate class	SN-T
Net capacity, total	207 l
Gross capacity, total	248 l
Voltage	220-240 V ~
Frequency	50 Hz
Connection rating	1.3 A 251 W

Dimensions and weight

Aperture height	178 cm
Dimension (packaged), H/W/D	1,877.0 / 575.0 / 622.0 mm
Aperture dimensions height/width/depth	177.2 - 178.8 / 56 - 57 / 55.0 cm
Weight (without packaging)	77.8 kg
Weight (with packaging)	83.2 kg

Control and Functions

Control	Magic Eye with LC and digital temperature display
Control unit	Touch-Electronic
Temperature display	Freezer compartment
Malfunction: Warning signal	Optical and acoustical
Door open: Warning signal, freezer compartment	Audible
Super Frost	Quantity-controlled
Soft System	Soft System

Freezer

Star-coding	4
Storage time during interruptions in power supply	14 h
Drawers	9
Storage shelf material, freezer compartment	Glass
Lighting	LED lighting
Cold storage accumulators	2
Frost Safe-System	With completely enclosed, transparent drawers

Set up and installation

Door assembly	Door-on-door
Door hinges	Left interchangeable
Door opening angle	115°
Ventilation	Kitchen unit ventilation

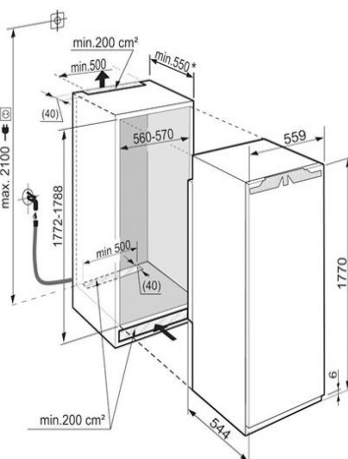

CONTACT :
MOBILE :
E-MAIL :

MVP APPLIANCES
No. 1,11 B Street, Al Quoz Industrial Area 4, Dubai - UAE
Tel : +971 4 380 9490 | Fax : +971 4 346 5614
WEBSITE: www.mvpappliances.com