



PROJECT	<input type="text"/>	DETAILED SPECIFICATIONS	<input type="text" value="REFRIGERATOR / FREEZER WITH BIO FRESH"/>
LOCATION	<input type="text"/>	ITEM CODE	<input type="text" value="ECBN 6256 PREMIUM"/>
FINISH	<input type="text" value="SILVER"/>	MANUFACTURE	<input type="text" value="LIEBHERR"/> DATE <input type="text" value="22/09/2023"/>

Features



Output and Consumption

Energy efficiency class	A++
Energy consumption in 24h	0.881 kWh / 24h
Energy consumption per year	322 kWh/a
Climate class	SN-T
Noise level	42 dB
Net capacity, total	471 l
Refrigerator compartment	357 l
of which BioFresh	68 l
Freezer compartment	114 l
Gross capacity, total	585 l
Refrigerator compartment	402 l
of which BioFresh	73 l
Freezer compartment	183 l
Voltage	220-240 V ~
Frequency	50 Hz
Connection rating	1.5 A 194 W

Dimension and Weight

Aperture height	203 cm
Dimension (packaged), H/W/D	2,125.0 / 966.0 / 750.0 mm
Aperture dimensions height/width/depth	203.2 - 207.2 / 91.5 / 62.5 cm

Control and Functions

Control	Digital temperature display in the MagicEye
Control unit	Touch-Electronic
Individual temperature zones	2
Temperature zones	3
Temperature display	Refrigerator- & freezer compartment
Malfunction: Warning signal	Optical and acoustical

Refrigerator Compartment

Defrosting method	Automatic
Lighting	LED light column and LED ceiling lighting
Number of storage shelves, refrigerator compartment	4
Storage shelf material, refrigerator compartment	Glass
Number of can racks	4
Number of BioFresh safes	2
of which HydroSafe	2
with lighting	LED lighting

Freezer Compartment

Storage time during interruptions in power supply	40 h
Freezing capacity in 24 hrs	11 kg
Drawers in freezer compartment	2
Lighting	LED lighting

Set - up and Installation

Door assembly	Door-on-door
Door hinges	Left fix/right fix

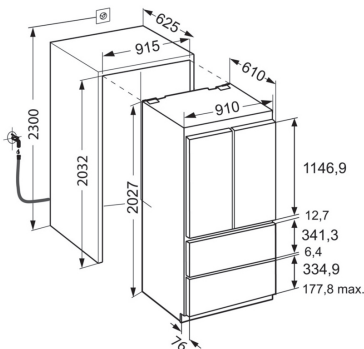

CONTACT :
MOBILE :
E-MAIL :

MVP APPLIANCES
No. 1,11 B Street, Al Quoz Industrial Area 4, Dubai - UAE
Tel : +971 4 380 9490 | Fax : +971 4 346 5614
WEBSITE: www.mvpappliances.com